

## FAN BELT

1. OIL RESISTANT SQUARE WOVEN FABRIC – Reduces surface fatigue and resists cracking, oil and heat.
2. TREATED POLYESTER CORD – Muscled with high strength, low stretch tension member for long flex life and greater resistance to shock loads.
3. FIBRE REINFORCED INSULATION – Gives high strength in the transverse direction and high flexibility in the longitudinal direction.
4. MOULDED COG CONSTRUCTION – Deep cogs to quickly dissipate heat. These cogs are 50% of the belt thickness to eliminate angle change when flexing (a major source of wear).

### INSTA-FIND<sup>®</sup>

#### BELT NUMBERING SYSTEM

The INSTA-FIND system is simplicity itself – and this is how it works:

##### THE PART NUMBER IS THE BELT SIZE

With the Goodyear INSTA-FIND system the part number is the belt size in millimetres. The belts are hung by "top width" and "length" which automatically puts them in numerical order. This means the required size can be found in an instant.

##### TOP WIDTH

The first two numbers indicate the belt top width in millimetres. Thus 13AV equals 12.5 mm top width.

##### LENGTH

The last four numbers signify the overall effective length of the belt in millimetres. Therefore 1300 equals 1300 mm effective length. It follows that a belt identified as 13AV1300 HD has a 12.5 mm top width and a 1300 mm effective length.

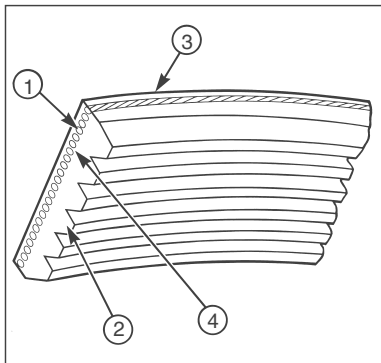

## MULTI RIB BELT

The multi-rib belt design features the power transmission capabilities of V-belt with the flexibility of flat belt. This belt runs cooler and lasts longer than the standard automotive fan belt. Even distribution of pressure over all parts of the drive surface provides uniform load distribution, smoother running, better tolerance to shock loads and greater stability – resulting in longer life.

1. TENSION MEMBER – The treated polyester cord is a low stretch high strength tension member able to withstand shock loads on drives with fixed centres.
2. RUBBER RIBS – Long wearing, fibre-loaded, heat resistant synthetic rubber is used in the ribs to provide support for the tension member and to transmit the loads to the pulley.
3. BACKING MATERIAL – Bias ply type fabric backing resists cracking and provides abrasion resistance.
4. INSULATION MATERIAL – Heat resistant rubber is used to bond the tension member to the rest of the belt.

### INSTA-FIND<sup>®</sup>

#### BELT NUMBERING SYSTEM

The multi-rib range of Goodyear's belts follow the well tried INSTA-FIND system of using the physical size of the belt as the part number. They fit into sleeves and can be hung on the finger racks alongside the high temperature compound fan belts to give an unbeatable and most complete range.

##### NUMBER OF RIBS

The first digit gives the number of ribs. Thus 6 means 6 ribs.

##### RIB SECTION

The letters give the section of the ribs and a "P" shows that the length is in millimetres. Thus "PK" means an automotive section belt with length shown in millimetres.

##### LENGTH

The final numbers give the effective length of the belt either in inches (no "P" in the rib section) or millimetres (inclusive of "P" in the rib section). Thus 0863 is 863 mm effective length.

Therefore a 6PK0863 HD is 6 ribs of automotive K-section and 863 mm effective length.

##### NOTICE!

Whilst the INSTA-FIND system makes it possible to substitute a belt with another of close length, it is most important that the number of ribs is correct. Never use a belt with the wrong number of ribs!

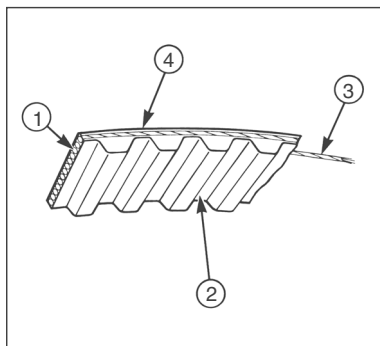

## AUTOMOTIVE TIMING BELT

1. **PRECISION MOULDED TEETH** – Compounded of tough, shear-resistant rubber, the teeth on timing belts are moulded to close tolerances on pitch and length.
2. **TOUGH NYLON FACING FABRIC** – The facing used on the tooth side of timing belts is made of tough, specially woven nylon fabric that has been chemically treated to reduce pulley friction and impregnated with abrasion, oil and ageing resistant synthetic rubber.
3. **LOAD CARRYING CORDS** – The load carrying members in timing belts are made of extra strong glass fibre or Flexten cords. These cords are dimensionally stable, ensuring that the length of a belt never changes and that the belt teeth are always perfectly meshed with pulley grooves.
4. **SPECIFIC COMPOUNDS** – The compounds specially selected by Goodyear from Polychloroprene or HNBR are driven by modern engine needs and give durable, smooth running and age resistant properties.

### INSTA-FIND<sup>®</sup> BELT NUMBERING SYSTEM

The numbering system is simple and easy – the belt number is the size.

**THE FIRST NUMBERS** – These numbers indicate the number of teeth on the belt. Thus 100 means 100 teeth.

**THE CENTRE LETTERS** – These letters or combination of letters and numbers gives the pitch of the teeth and the type of teeth employed. Thus LH is an 'L' type belt with 'H' type cord.

**THE FINAL NUMBERS** – These numbers indicate the width of the belt in millimetres x 10. Thus 170 means 17 mm wide.

#### NOTE

For ease of timing belt ordering and stocking, Goodyear has added a simple reference number to the box.

e.g. G1299H/HD.

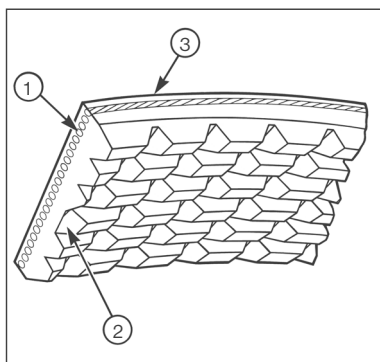

## GATORBACK POLY-V BELT

The Gatorback Poly-V belt features the power transmission capabilities of standard Poly-V belt with added flexibility, producing a cooler running belt with a tighter pulley grip and providing extended belt life.

1. **TENSION MEMBER** – Strong, stretch-resistant tension member is specially treated to maintain tension and resist stretch on both locked center drives and spring tension systems.
2. **TOUGH SYNTHETIC HELICAL COGGED RUBBER RIBS** – Fibre-reinforced heat resistant synthetic rubber, helical cogged ribs offer maximum cord support and wear resistance for unsurpassed performance in transmitting the loads to the pulley. The diagonal Helicog™ teeth gives the Gatorback Poly-V belt added flexibility, which translates into a cooler running belt that lasts longer and reduces the chirp noise at low temperatures and extreme moisture conditions.
3. **BACKING MATERIAL** – Heat and abrasion-resistant backing on every Goodyear Gatorback Poly-V belt is tough coated fabric material. It's impregnated with high temperature resistant rubber for heat and wear resistance to provide the high coefficient of friction needed to drive flat pulleys.

### INSTA-FIND<sup>®</sup> BELT NUMBERING SYSTEM

The Gatorback Poly-V range of Goodyear's belts follow the well tried INSTA-FIND system of using the physical size of the belt as the part number.

#### NUMBER OF RIBS

The first digit gives the number of ribs. Thus 6 means 6 ribs.

#### RIB SECTION

The letters give the section of the ribs and a "P" shows that the length is in millimetres. Thus "PK" means an automotive section belt with length shown in millimetres.

#### LENGTH

The final digits give the effective length of the belt in millimetres (inclusive of "P" in the rib section). Thus 0863 is 863 mm effective length.

#### GATORBACK

The final letter "G" designates the Gatorback Helicog tooth design.

Therefore a 6PK0863G is 6 ribs of automotive K-section and 863 mm effective length with Gatorback ("G") Helicog tooth design.

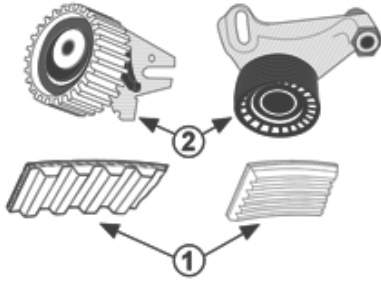

1. TIMING BELT or POLY-V BELT
2. CORRESPONDING METAL PARTS

## TIMING BELT / POLY-V KITS

Problems with the idlers/tensioners and their bearings in an accessory drive can cause premature belt failure. The best way to ensure a reliable drive system is to change the belt and metal parts at the same time. Goodyear's range of timing and poly-V bel

Goodyear timing and poly-V belt kits contain the highest quality components specific to each Automotive application.

### **INSTA-FIND**<sup>®</sup> KIT NUMBERING SYSTEM

THE FIRST LETTER AND NUMBER («K1...», K2...») - the letter («K») indicates kit, the number that follows identifies the different combinations of belt and metal parts.

SYMBOLS THAT FOLLOW - these combinations of numbers and letters identify the belt. Please refer to timing and Poly-V belt numbering system.

Therefore a K1 G1045H is Kit No.1 and timing belt reference number G1045H; a K1 4PK1260 is Kit No.1 and Poly-V belt 4PK1260.

If you want to order a kit, you need to specify both the reference indicated in the column 'KIT' and the belt reference indicated in the column identified by a belt, e.g. K1G1171. If you need the belt only, you order the belt reference only, e.g. G1171.